





# CRANE



Available in:

### Features & Benefits



120W



- Robust pressure die cast aluminium body.
- Pluggable connector
- IK10
- Suitable for side mounting with 60mm spigot
- Suitable for 50°C Ambient
- Chip Type CREE
- Lumen Efficacy >100, CRI >70
- Provided with Surge Protection Device



140W



210W

#### APPLICATIONS:

Urban expressway, trunk road, secondary roads, slip roads, factories, schools, gardens, squares, courtyards, parking lots etc.





# CRANE

Light Distribution Curve

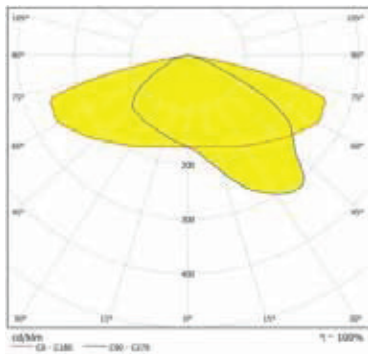

Dimension Diagram

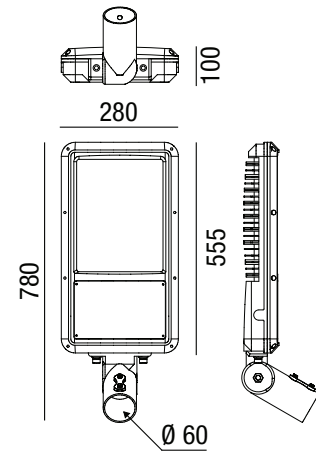

## Specification

Ordering Code	Part Code	Description	Watts (W)	CRI	CCT* (K)	Input Voltage (VAC)	Frequency (Hz)	PF	LM/W	Lumens (lm)	Life (hrs)	Std Pack	Power Factor	Operating Temperature Range	Operating Humidity Range	IP Rating
RC4-120	500150011265001	Die cast Aluminium Street Light / LED	120	70	3500/4000/6500	220-240	50-60	0.95	130-150	18000	100,000	1	0.95	-40 <sup>0</sup> c - 50 <sup>0</sup> c	10%-90%RH	IP66
RC4-140	500150011465001	Die cast Aluminium Street Light / LED	140	70	3500/4000/6500	220-240	50-60	0.95	130-150	21000	100,000	1	0.95	-40 <sup>0</sup> c - 50 <sup>0</sup> c	10%-90%RH	IP66
RC4-210	500150012165001	Die cast Aluminium Street Light / LED	210	70	3500/4000/6500	220-240	50-60	0.95	130-150	31500	100,000	1	0.95	-40 <sup>0</sup> c - 50 <sup>0</sup> c	10%-90%RH	IP66